

- (4) Assuming your switch machines are connected properly, tapping the button in the State column will toggle the state of the switch machine between closed and thrown.
- (5) You can also click on each entry in this list to edit the names, DCC addresses, reversed state and DCC reversed. DCC addresses are relevant if you connect a DCC Command Station/Booster or use the WFD-60 WiThrottle/DCC gateway. Stall-motor mode can also be set to bipolar or simple on/off positive or negative.

## Getting more out of your WFS-87

Please do consult the full manual for information about the great features available. For example, you can:

- Use the Home Net option. That way you can leave you phone or tablet connected to your home network. When you power up your WFS-87, your phone or tablet will connect much more quickly.
- Explore the WFS-87 web pages to see the features available.
- Use the WFD-60 Gateway to control switches using WiThrottle, Engine Driver or Loco Operator, while driving trains.
- Use Tower Operator to configure a schematic control panel to control your switches and select routes.
- Access the WFS-87 Manual at <http://www.wifitrax.com/manuals/WFS-87/WFS-87-Manual.pdf>

## More Information

<http://www.wifitrax.com/help/TowerOperator/help.html>

Other resources:

<http://www.wifitrax.com/appNotes/howToArticles.html>

**This product is not a toy. Keep away from children. It is not suitable for use by persons under 14 years of age.**

**Warning: This product contains chemicals known to the state of California to cause cancer, birth defects or other reproductive harm.**

WifiTrax products are made in Australia using globally-sourced components and services. Check our website for warranty information.

WifiTrax Model Science [www.wifitrax.com](http://www.wifitrax.com)

# WifiTrax

[www.wifitrax.com](http://www.wifitrax.com)



## WFS-87 Getting Started Guide

This document is online at <http://www.wifitrax.com/appNotes/quickStart/WFS-87-Quick-Start.pdf>. Please consult the full WFS-87 manual for much more detail at <http://www.wifitrax.com/manuals/WFS-87/WFS-87-Manual.pdf>

### Package Contents

1 x WFS-87 Module in Static Shielding Bag, this document, mounting Kit

## WFS-87 8-Way Universal Switch Controller

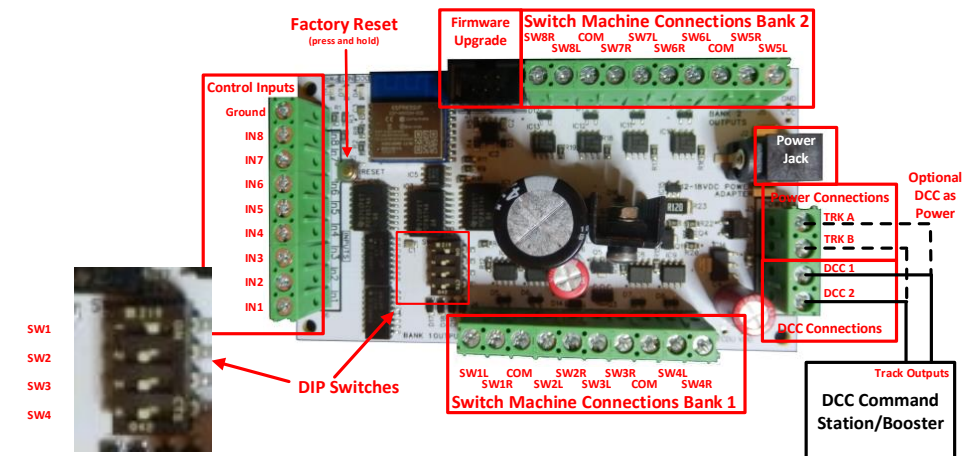

Figure 1 WFS-87 Connections

Switch	ON Function	OFF Function	Remarks
SW1	Twin Coil Mode	Stall Motor Mode	Mode Switch
SW2, SW3 SW4		See Table 2	

Table 1 DIP Switch Settings

The WFS-87 provides control for up to 8 switch machines, either coil or stall motor type. It can be operated through its web browser interface, from a DCC command station, or using WifiTrax Tower Operator app. With the addition of WifiTrax WFD-60 Gateway, switches can also be operated using such WiThrottle protocol devices as WiThrottle on

WifiTrax Model Science [www.wifitrax.com](http://www.wifitrax.com)

SW2	SW3	SW4	Output Voltage	
			SW1 = ON (Twin Coil Mode)	SW1 = OFF (Stall Motor Mode)
OFF	OFF	OFF	Up to 24V	Approx. (Track Voltage – 3V)
ON	OFF	OFF	19V	Approx. (Track Voltage – 3V)
OFF	ON	OFF	12V	12V
OFF	OFF	ON	9V	9V

Table 2. Voltage DIP Switch Settings

Apple, Engine Driver on Android or the TCS UWT-100 Universal Wi-Fi Throttle. If you have a DCC System compatible with JMRI, you can also use JMRI to control your switches via the DCC inputs of the WFS-87. The module provides over-current protection when in Stall-Motor mode and three LEDs to indicate Power (red), Network (green) and DCC status (blue). Flashing blue also indicates over-current.

## Wiring for Different Switch Machine Types

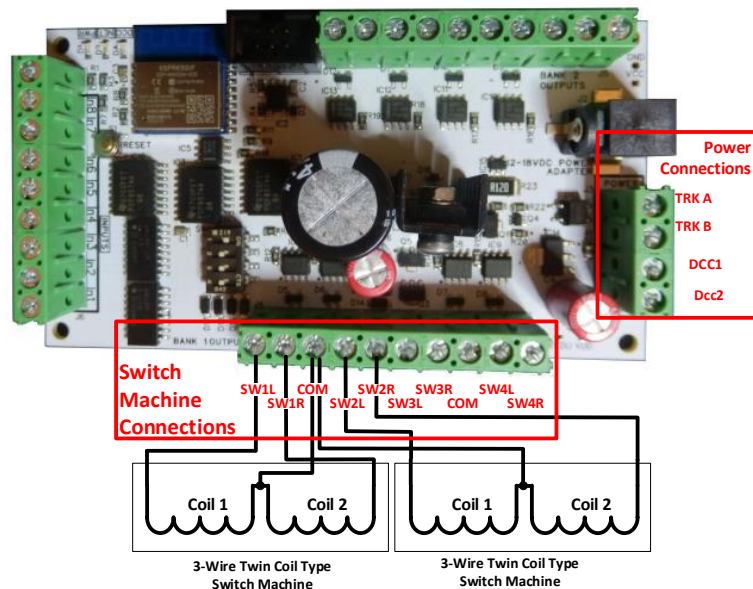

Figure 2. Connection Diagram for 3-Wire Twin Coil Switch Machines

- (2) Tap Connections, then Wi-Fi and select the module's network as above.

## Connecting using Windows

On your Windows 10 desktop or laptop, click the networks icon in the system tray and select the network described above.

## Using the Web Pages

- (1) Once you are connected to the module's network, open a browser such as Safari or Chrome and type the following in the URL bar followed by the Enter or Go key: 192.168.7.1  
This is the IP Address of the WFS-87 web pages when you are connected to its wftrx\_WFS87\_1\_XXXXXXX\_7 network.
- (2) You will see the Main Menu page as below:

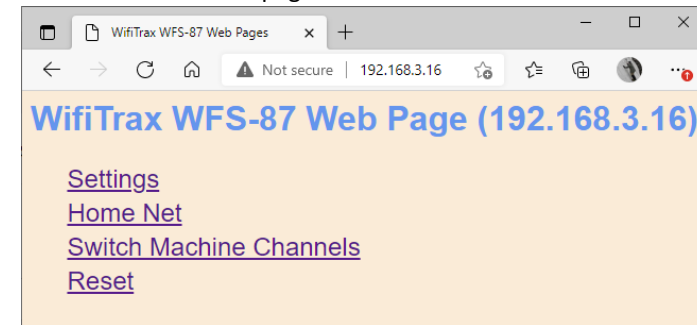

- (3) To test the switch machine channels, click or tap the Switch Machine Channels option. You will see the screen below. The names of each channel default to the serial number plus the channel number as shown:

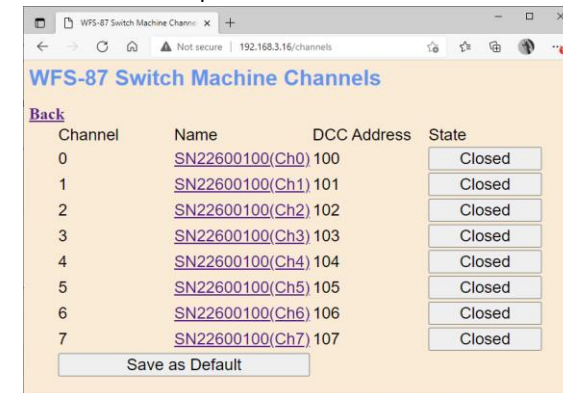

- (9) Mount the unit using the four M3 metric screws, nuts and spacers provided in the mounting kit. Mount the unit on a suitable piece of board, either your baseboard (top or bottom) or a separate board perhaps at the front of your model railroad. The component side of the module should face away from the board as in Figure 6. Take care that no part of the unit touches any metal as this may cause a short circuit and result in permanent damage. Do not mechanically stress or bend the module as this may cause permanent damage. **Take care to ensure that there is adequate ventilation to avoid overheating.**
- (10) **CHECK YOUR WIRING!** Turn on the power. If you have installed manual push buttons you may test the unit by pressing each button momentarily in turn. You can also test using a web browser on Apple IOS, Android or Windows as in the next section. Your DCC Command station is another option using accessory address that default to 100-107. Also refer to the Tower Operator Quick Start, or Full Help Pages for instructions on setting up a schematic control panel using Tower Operator on your Windows or Android computer or tablet.

## Testing and Configuring your WFS-87

You can test and configure the WFS-87 using its web pages which are accessible from any browser on IOS, Android or Windows.

### Connecting using an Apple IOS Phone or Tablet

- (1) Tap the Settings icon on your iPhone or iPad



- (2) Tap Wi-Fi on the left-hand menu. Under Other Networks on the right, the list should include one like wftrx\_WFS87\_1\_XXXXXXXX\_7, where XXXXXXXX is the serial number of your unit that appears on its label. Tap that Wi-Fi Network. **You must always connect to this Network to access the WFS-87 web pages** until you operate in home-net mode.

### Connecting using Android

- (1) Press the Home button and tap the Settings icon:

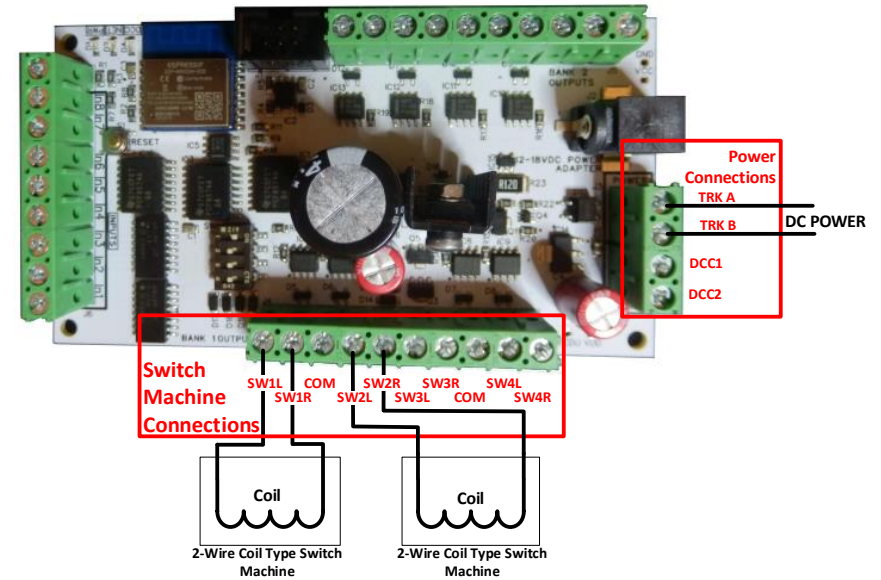

Figure 3. Connection Diagram for 2-Wire Coil-Type Switch Machines

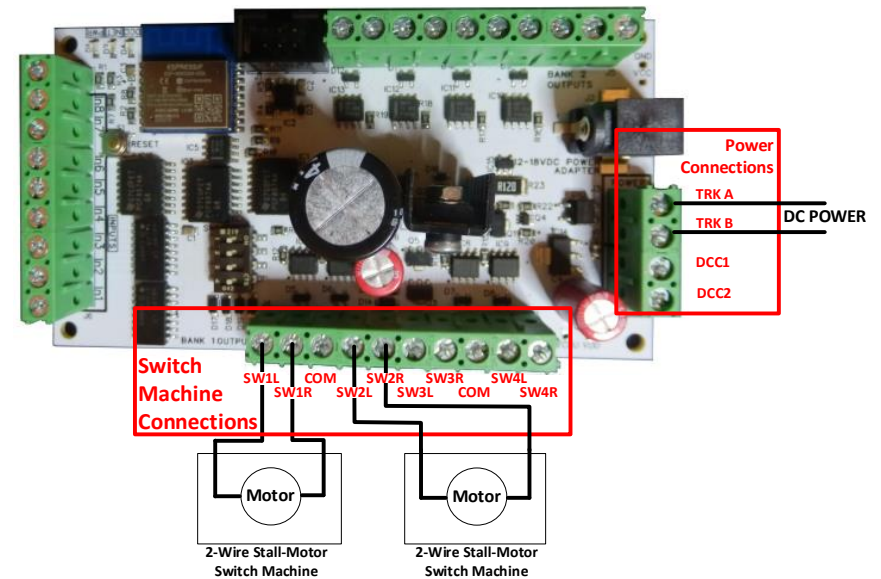

Figure 4. Connection Diagram for Stall Motor Switch Machines

# Wiring for Push Button Operation

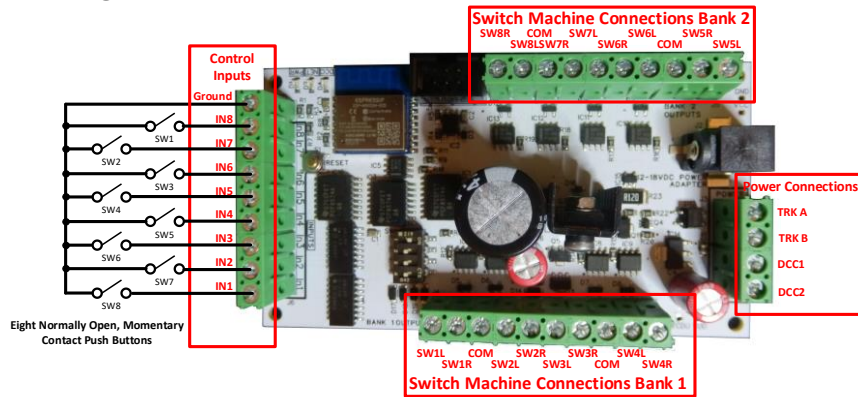

Figure 5. Connection Diagram for Manual Push Buttons

## Installation Instructions

- (1) First determine what kind of switch machines you wish to control. WFS-87 will control three basic types: 3-Wire Twin Coil, 2-Wire Coil-Type (Bipolar) and Stall Motor. **Any one WFS-87 module can control EITHER Stall Motor OR Coil-type but not both.**
- (2) Figure 1 shows the WFS-87 module with its connections and switches labelled. Configure the switches on your module for your choice of switch machine type as in Table 1 and Table 2. Please take great care that SW1 is in the correct position – ON only for coil-type solenoid switch machines, OFF for stall motor like Tortoise. A flashing blue LED usually indicates a stall-motor mode WFS-87 is connected to coil type switch machines. **If you connect the wrong type, you may damage either the switch machine or the WFS-87. Do not change any switch without first switching off the power!**

- (3) Configure switches SW4, SW5 and SW6 to provide the best output voltage for your switch machine. Some switch machines – Tortoise, for example – require that no more than 12 Volts be used.
- (4) Wire your module to the switch machines as shown in Figure 2 , Figure 3 or Figure 4. A WFS-87 can control eight switch machines. You can use each channel or leave it unconnected. You can mix 3-Wire and 2-Wire Coil-type Switch Machines on the same unit, but if you choose the stall-motor settings, all channels must be connected to stall-motor machines or left unconnected.
- (5) Connect power to your unit either at the Power Jack or at TRKA and TRKB as shown in Figure 2 , Figure 3 and Figure 4. It does not matter which way round you connect the power. You can also use DCC track power but NOT AC. The power should be between 12 and 18 volts. As an alternative to the TRKA and TRKB connections, you can connect a power adapter to the Power Jack marked in Figure 1.
- (6) The power adapter must supply between 12 and 18 Volts DC with a Barrel Plug (2.5mm I.D. x 5.5mm O.D. x 9.5mm). A recommended power adaptor is available from WifiTrax: <http://www.wifitrax.com/products/product-PA15-43-1-detail.html> **DO NOT CONNECT POWER TO THE WRONG TERMINALS. THIS MAY DAMAGE THE UNIT BEYOND REPAIR.**
- (7) Optionally, install up to eight normally open, momentary contact push buttons as shown in Figure 5.
- (8) Optionally connect a bipolar DCC signal to the DCC1 and DCC2 connections shown in Figure 1. If you are using DCC to control *and* provide power to the WFS-87 you should connect TRK A to DCC1 and TRKB to DCC2 together as shown.

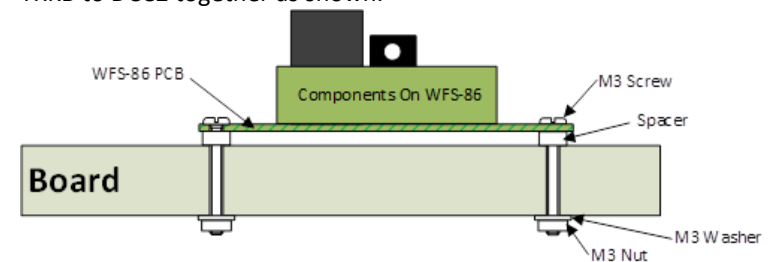

Figure 6 Mounting Suggestion